

Valving/devalving unit

ATEX version

EL60-ATEX model

In compliance with Directive 94/9/EC



Description

The Valving/devalving machine, EL60-ATEX, is included in the equipment classified as "group II" (as defined by Directive 94/9/EC): apparatus designed to work in sites that could be threatened by the presence of explosive atmospheres, not intended for use in underground mines and plants in their area, wherever a possible release of firedamp gas and / or combustible powders may happen.

The Valving machine EL60-ATEX is classified in "Category 2", making it suitable for operation in environments where an explosive atmosphere is expected to be formed caused by gas, vapors and mist. For this reasons, the machine is suitable to work in Zone classified as "1".

The equipment is also suitable to operate with gases belonging to "group IIC", namely the group of Acetylene.

The string marking the Valving machine EL60-ATEX shows the following:

CE EX II 2G c IIC T4 -5°C Ta +40°C

The type of ATEX certification chosen by the manufacturer is to "**control the internal production**" in Annex VIII for not electrical equipment as for Directive 94/9/EC.

For all the subgroups meeting the definition of apparatus" or "protection system" not produced by Vanzetti Equipment, their own manufacturers have provided the due EC declaration of conformity.



**USE IN PRESENCE OF POTENTIALLY
EXPLOSIVE ATMOSPHERES**

Valving/devalving unit ATEX version

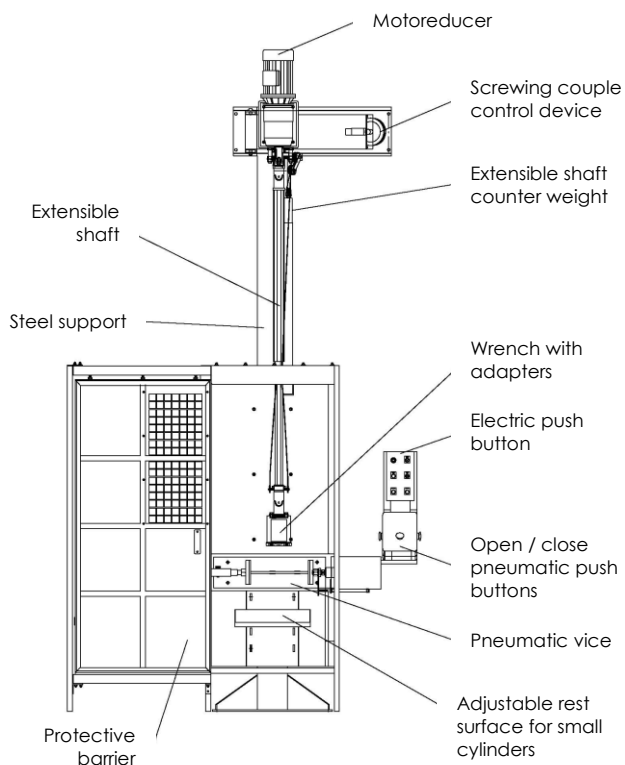

Complete equipment

TECHNICAL DETAILS

- > Standard required electrical supply: 400 V – 50Hz – three phase
- > Other three phase electrical supply on request (single phase supply not admitted)
- > Remote electrical control: 24V – 50 Hz
- > Adjustable screwing torque: 10 ÷ 40 Kg*m
- > Electrical motor power: 1,5 kW
- > Needed compressed air supply: 7 ÷ 8 bar
- > Cylinder accepted diameters: 80 ÷ 300 mm
- > Cylinder accepted height (valve included): 400 ÷ 1650 mm
- > Electrical control panel **ATEX** on board.
- > Electrical power panel **NON-ATEX** to be installed in a not classified area.

Dimensions / Weight

Overall dimensions: 2000 x 800 x (h) 3960 mm

Weight

Total: 600 Kg approx

Noise:

Less than: 85 db

STANDARD ACCESSORIES INCLUDED

- > Use and maintenance manual
- > Insert key
- > Insert: type "A" – "C10" – "C12" for valve square shaped 30 and 32 mm
- > Adjustable and removable cylinder support for small cylinders.

On request:

Additional insert for valve square shaped from 14 to 48 mm.

> PER MAGGIORI INFORMAZIONI:
FOR FURTHER INFORMATION CONTACT:
POUR INFORMATIONS CONTACTER:

VANZETTI EQUIPMENT S.r.l.
Via Avv. Giovanni Agnelli, 10 12033 MORETA (CN) ITALY
Tel. +39 0172 915806
Fax +39 0172 915822

info@vanzettiequipment.com
www.vanzettiequipment.com



BULLETIN N° VE/EL60EX-R1.14-E